

Installation Instructions

Thank you for purchasing our Low Profile Rail Tonneau System. Saddleman, Inc. has constructed this rail tonneau system using the finest quality materials and craftsmanship available. Given proper care, your rail tonneau system will give you years of service.

TOOLS REQUIRED: # 2 Phillips Screw Driver
Allen Wrench - Included in box

NOTE: The Low Profile System does not work with Over-the-Rail Bedliners.

For Under-the-Rail Bedliners, trim enough of the front liner so that the rails mount flush with the truck bed without the liner impeding the front rail placement. In several cases, the tailgate liner may need to be removed.

Installation Tips

1. For additional ease of installation, install your rail tonneau in temperatures above 70°F (21°C).
2. Please read all instructions before installing the cover. You should allow about 30 minutes to complete the installation.
3. Wash your truck to ensure that no dirt or abrasive materials are caught between your truck's finish and the tonneau rail frame.
4. It is normal for your tonneau cover to contract and wrinkle in the shipping carton. The cover will expand and the wrinkles will disappear within a few days after installation.
5. If you encounter any problems during the installation, please contact our Customer Service Department, Monday - Friday, 7AM - 6PM (MST) at 1-801-752-1000.

Unpacking the Contents of the Shipping Package.

Remove all parts from the shipping container. Check each part included against the following Parts List:

Parts List

1 Rail Assembly - Front	Installation Clamps:
1 Rail Assembly - Rear	Long Bed - Includes 8 Clamps and 9 Set Screws
1 Rail Assembly - Side, Right	Short Bed - Includes 6 Clamps and 7 Set Screws
1 Rail Assembly - Side, Left	4 Corner Attachments (Pre-attached to side rails)
1 Bow Assembly	5 Set Screws for final attachment of corner bracket
1 Vinyl Cover	

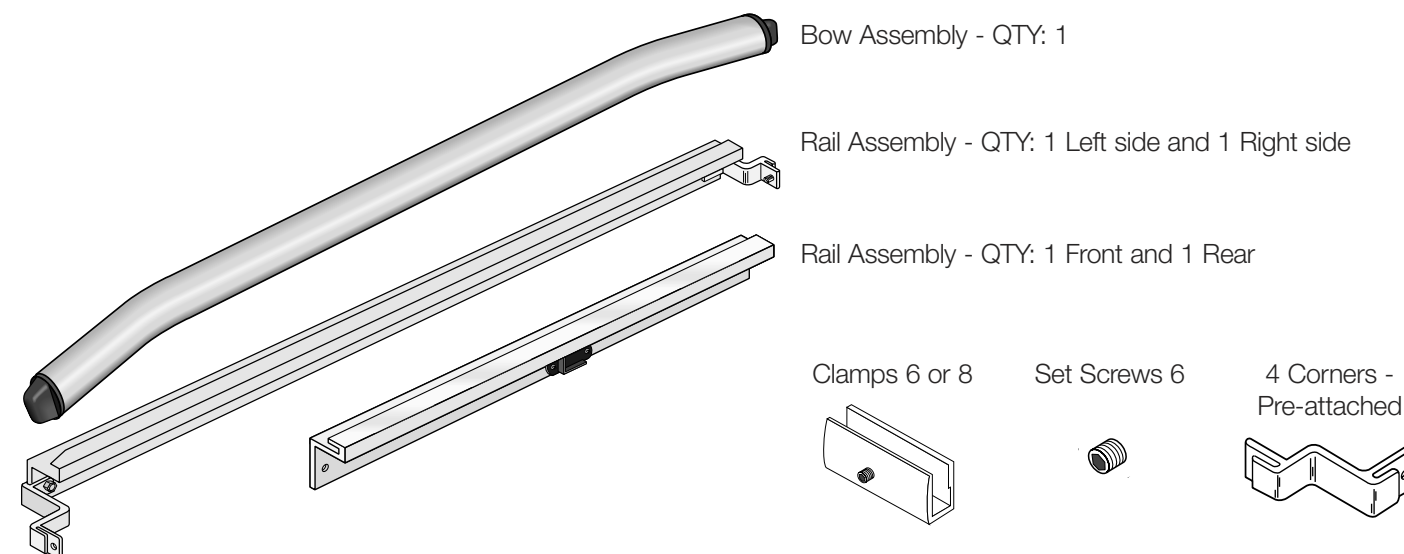

Step 4.

Installing the tonneau cover

The plastic strips along all four sides of the tonneau cover fit into the groove of the rail assembly.

Roll out tonneau cover and position over the rails. Be sure the cover is centered front to back and side to side. The **pull tab** must be in the rear of the rail assembly.

- Starting at the front rail (Cab side), insert the plastic strip in the rail by standing the strip up against the rail and pushing flat (Fig. 6). Install the front rail cover completely.
- Go to the rear rail (tailgate side), and install the rear rail completely. Be sure the cover is tight and all four corners are covered.
- Then finish by working down the side rails. The cover is sized for a long term fit. It will be tight initially and loosen slightly with use.

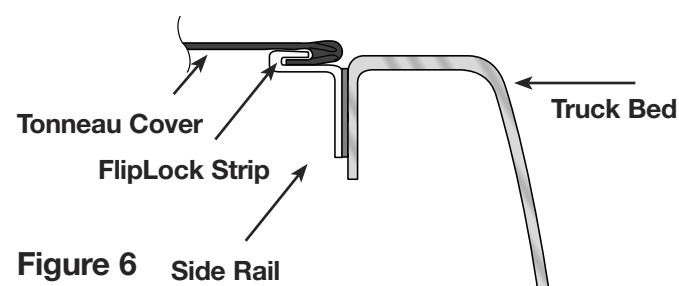

Figure 6 Side Rail

Removing the cover

To remove cover, use the tab (left rear corner) and ease the plastic strip out of the rail by pulling DOWN and OUT. Then peel the plastic strip out of the remainder of the rail.

To remove cover entirely, remove the bow from the rear, this will allow you to push in rear rail, easing tension and releasing the cover.

To fasten cover repeat step 4.

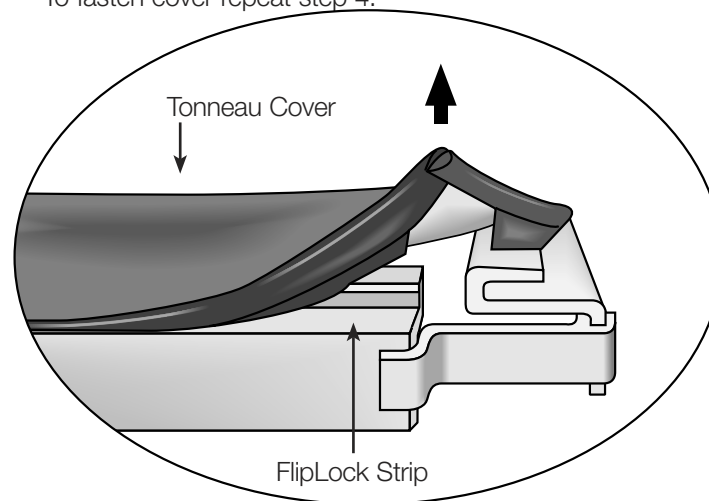

Note: If you encounter any problems during the installation, please contact our Customer Service Department, Monday through Friday, 7:00 AM to 6:00 PM MST at 1-801-752-1000.

Care Instructions

- A. Wash your tonneau cover with warm water and a mild soap. DO NOT USE OIL BASED PROTECTANTS OR SILICONE BASED PRODUCTS.
- B. Tonneau cover must be secured at all points when vehicle is moving. A tonneau cover that is unsecured will flap, resulting in damage to the vinyl fabric.
- C. Do not overload bed of truck. Stress on tonneau cover fabric could result in damage.
- D. The Low Profile rail tonneau system is not designed to be waterproof and will not keep water out of the truck bed.

For Replacement Parts, Please See Your Local Retailer Where You Purchased Your Rail Tonneau

LIMITED WARRANTY

We warrant our product to be free from defects in material or workmanship, for the term specified below, provided there has been normal use and proper maintenance. This warranty applies to the original purchaser only. All remedies under this warranty are limited to the repair or replacement of any item or items found by the factory to be defective within the time period specified.

If you have a warranty claim, first you must call our factory at the number below for instructions. You must retain proof of purchase and submit a copy with any items returned for warranty work. We will return the repaired or replaced items to you freight prepaid. Damage to our products caused by accidents, fire, vandalism, negligence, misuse, Acts of God, or by defective parts not manufactured by us, are not covered under this warranty.

THE TERMS OF OUR WARRANTY ARE AS FOLLOWS: **A.** RAIL TONNEAU SYSTEM HARDWARE KIT (CLAMPS, RAILS, BOWS) FULL LIFETIME OF OWNERSHIP BY THE ORIGINAL PURCHASER.

B. TONNEAU COVER IS WARRANTED FOR ONE YEAR FROM THE DATE OF PURCHASE.

ANY IMPLIED WARRANTIES OF MERCHANTABILITY AND/OR FITNESS FOR A PARTICULAR PURPOSE CREATED HEREBY ARE LIMITED IN DURATION AS THE EXPRESS WRITTEN WARRANTY. OUR COMPANY SHALL NOT BE LIABLE FOR ANY INCIDENTAL OR CONSEQUENTIAL DAMAGE, INCLUDING, WITHOUT LIMITATION, DAMAGES RESULTING FROM THE USE OF THE PRODUCT ON REPAINTED SURFACES (NON-FACTORY ORIGINAL PAINT) AND FADING AND PAINT COLORATION DIFFERENCES RESULTING FROM THE PRODUCTS SHIELDING PORTIONS OF SURFACES FROM EXPOSURE TO THE SUN AND ELEMENTS WHILE OTHER ADJACENT SURFACES REMAIN COMPLETELY EXPOSED. THIS WARRANTY IS LIMITED TO FUNCTIONALITY OF PRODUCT, NOT COSMETIC RELATED ISSUES.

Some states do not allow limitations on how long an implied warranty lasts, or the exclusion or limitation of incidental or consequential damages, so the above limitations or exclusions may not apply to you. This warranty gives you specific legal rights, and you may also have other rights which vary from state to state. For further information or request for warranty work, please contact:

The Low Profile Rail Tonneau System is designed to assemble easily in about 30 Minutes.

Be Sure your truck is clean.

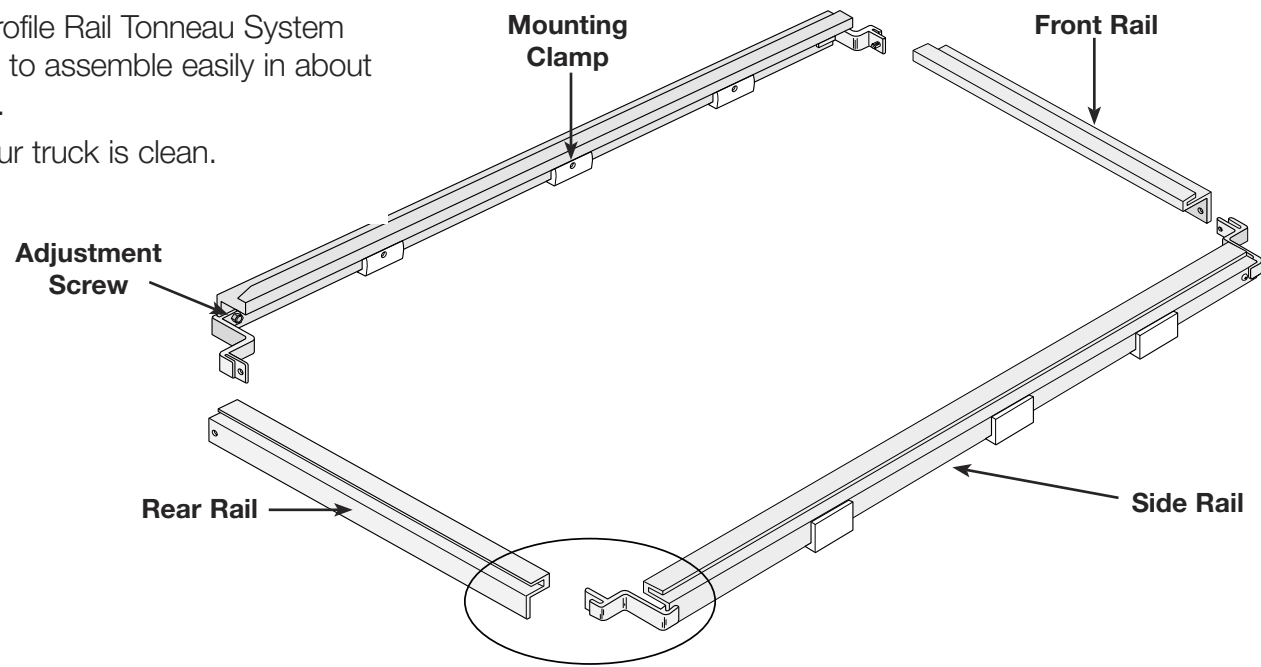

Step 1.

Mounting the Left Side Rail

1. Before you start installing, check the length of the side rail to the inside of the bed, if you need to lengthen the side rail, peel the foam tape back and loosen the screw that attaches the clamp to the side rail. Adjust the length so there is an 1/8" between the rail and bed. **RETIGHTEN AND REPLACE TAPE.**

2. Remove paper from tape on the rails.

POSITIONING THE CLAMPS:

3. **For Short Bed 3 Clamp Installation** - Set one clamp in the center of the rail. Set the others six inches from each end.

For Long Bed 4 Clamp Installation - Set the center clamps equally apart from each other with the end clamps six inches from each end.

SEE FIGURE 1.

INSTALLING SIDE RAIL TO TRUCK:

4. Position the rail on the truck, as in Figure 1, so that the "Back" label is at the tailgate end of the truck and there is a 1/8" gap between the rail ends and the bed.

5. From underneath the side rail, slide the mounting clamp up onto the rail and lip of the truck in the center of the bed.

6. Make sure the clamp is touching the bottom lip of the truck and the highest point of the rail is level with the top of the bed. **SEE FIGURE 2.**

7. Tighten the clamp with the enclosed Allen wrench. **DO NOT OVER TIGHTEN.**

8. Fit one of the mounting clamps 6 inches from the front end of the rail and tighten. Fit the other clamp 6 inches from the back end of the rail and tighten. **DO NOT OVER TIGHTEN.**

9. **REPEAT STEPS FOR OTHER SIDE.**

CHECK THE CLAMPS EACH MONTH FOR TIGHTNESS.

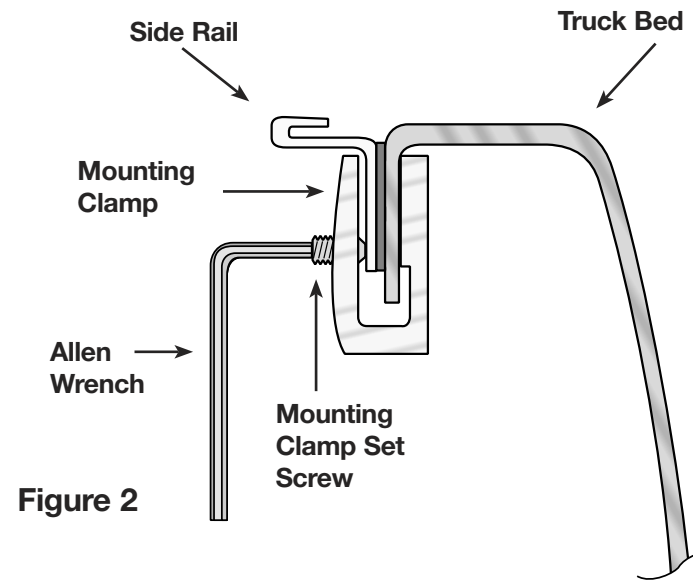
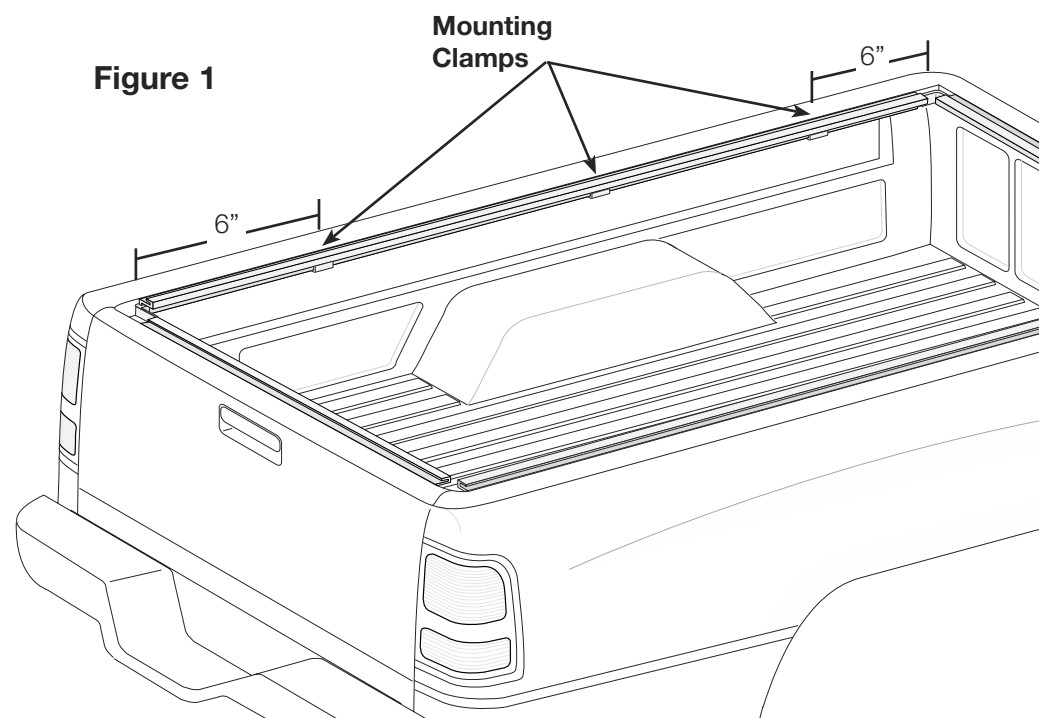

Figure 2

Step 2.

Mounting the Front (Cab Side) and Rear (Tailgate side) bed rails.

Remove the paper film from the front cross rail (marked front.) Remember - you must keep the rail tonneau frame rectangular at all times. Slide the front rail (cab side) into the brackets of the right and left side rails. Hint: Slide the front rail into the left and right corner brackets at the same time. Repeat for the rear rail.

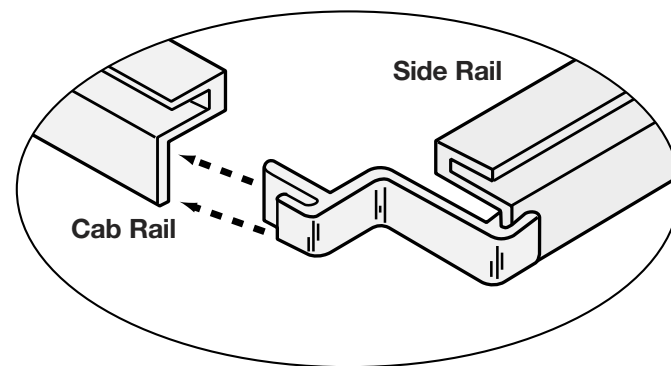

Figure 3

Install the set screws (Fig. 4) into the brackets and tighten lightly.

DO NOT OVER TIGHTEN.

REPEAT STEP 2 FOR THE REAR RAIL.

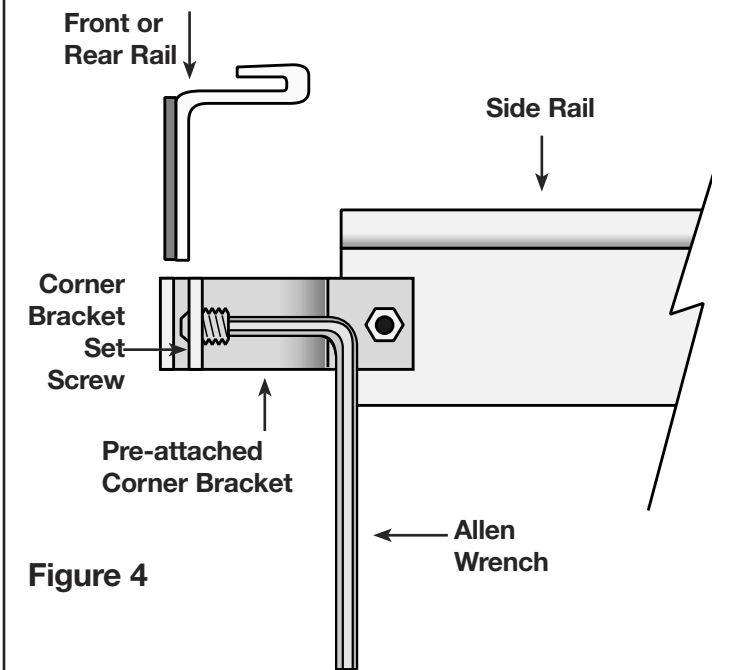

Figure 4

Step 3.

Installing the bow

Install the bow in the black bow brackets. Place one end in the front bow bracket (Fig. 5) and the other end in the rear bow bracket.

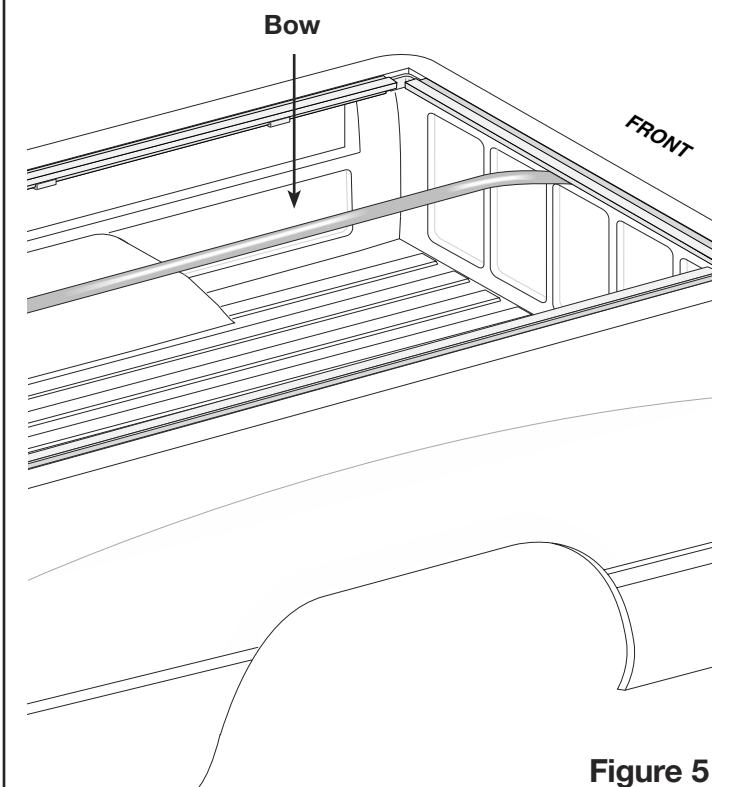

Figure 5