

Installation Instructions

Thank you for purchasing our Ultra-Lift Rail Tonneau System. Saddleman, Inc. has constructed this rail tonneau system using the finest quality materials and craftsmanship available. Given proper care, your rail tonneau system will give you years of service.

TOOLS REQUIRED: # 2 Phillips Screw Driver
Allen Wrench - Included in box

NO DRILLING IN THE TRUCK BED IS REQUIRED

Installation Tips

1. For additional ease of installation, install your rail tonneau in temperatures above 70°F (21°C).
2. Please read all instructions before installing the cover. You should allow about 30 minutes to complete the installation.
3. Wash your truck to ensure that no dirt or abrasive materials are caught between your truck's finish and the tonneau rail frame.
4. It is normal for your tonneau cover to contract and wrinkle in the shipping carton. The cover will expand and the wrinkles will disappear within a few days after installation.
5. If you encounter any problems during the installation, please contact our Customer Service Department, Monday - Friday, 7AM - 6PM (MST) at 1-801-752-1000.

Unpacking the Contents of the Shipping Package.

Remove all parts from the shipping container. Check each part included against the following Parts List:

Parts List

1 Rail Assembly - Front	2 Clamp-on Strut Brackets
1 Rail Assembly - Rear	2 Screw-on Strut Brackets
1 Rail Assembly - Side, Right	2 Snap Clamps
1 Rail Assembly - Side, Left	2 Struts
2 Bow Assembly	5 Set Screws for final attachment of corner bracket
1 Vinyl Cover	2 Rail Clamps

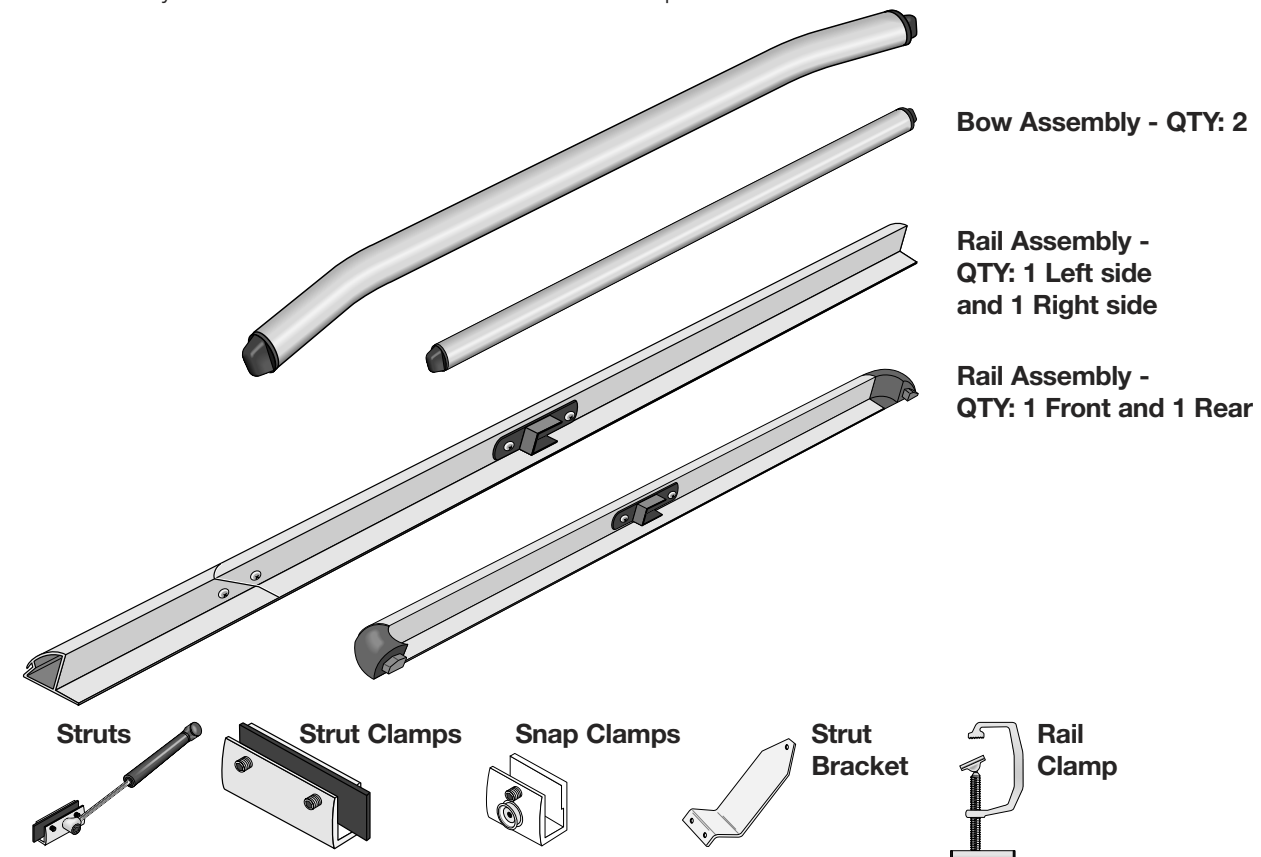

Step 7.

Installing the tonneau cover

The plastic strips along all four sides of the tonneau cover fit into the groove of the rail assembly.

Roll out tonneau cover and position over the rails. Be sure the cover is centered front to back and side to side. The **pull tab** must be in the rear of the rail assembly.

- Starting at the front rail (Cab side), insert the plastic strip in the rail by standing the strip up against the rail and pushing flat (Fig. 5). Install approximately 6 inches of the cover.
- Go to the rear rail (tailgate side), and install approximately 6 inches of the cover. Be sure the cover is tight and all four corners are covered.
- Install the front rail cover completely.
- Then work down the side rails.
- Finish with the rear rail portion at the corner. The cover is sized for a long term fit. It will be tight initially and loosen slightly with use.

Removing the cover

To remove cover, use the tab (left rear corner) and ease the plastic strip out of the rail by pulling DOWN and OUT. Then peel the plastic strip out of the remainder of the rail. To remove cover entirely, remove the bow from the rear, this will allow you to push in rear rail, easing tension and releasing the cover.

To fasten cover, repeat step 7.

Figure 5

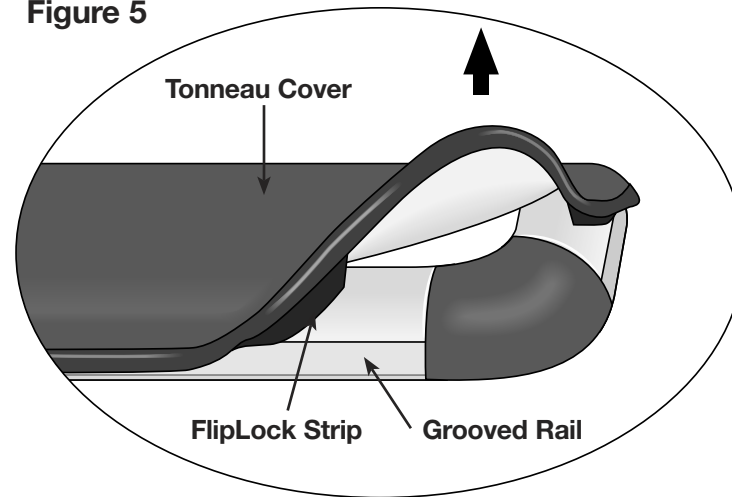

Care Instructions

- A. Wash your tonneau cover with warm water and a mild soap. DO NOT USE OIL BASED PROTECTANTS OR SILICONE BASED PRODUCTS.
- B. Tonneau cover must be secured at all points when vehicle is moving. A tonneau cover that is unsecured will flap, resulting in damage to the vinyl fabric.
- C. Do not overload bed of truck. Stress on tonneau cover fabric could result in damage.

For Replacement Parts, Please See Your Local Retailer Where You Purchased Your Rail Tonneau

Step 8.

Attaching the Snap Clamp

Close the tonneau cover and position the snap clamp on the lip of the truck's bed rail so it aligns with the snap strap attached to the tonneau cover.

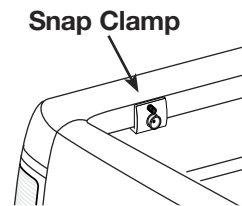

Be sure to place the black plastic strip between the set screws and your truck bed to prevent any paint damage.

Tighten the clamp with the Allen wrench included.

To operate, after the rail frame and cover has been lowered, take straps with sewn in buttons and snap into each snap clamp.

Note: If you encounter any problems during the installation, please contact our Customer Service Department, Monday through Friday, 7:00 AM to 6:00 PM MST at 1-801-752-1000.

LIMITED WARRANTY

We warrant our product to be free from defects in material or workmanship, for the term specified below, provided there has been normal use and proper maintenance. This warranty applies to the original purchaser only. All remedies under this warranty are limited to the repair or replacement of any item or items found by the factory to be defective within the time period specified.

If you have a warranty claim, first you must call our factory at the number below for instructions. You must retain proof of purchase and submit a copy with any items returned for warranty work. We will return the repaired or replaced items to you freight prepaid. Damage to our products caused by accidents, fire, vandalism, negligence, misuse, Acts of God, or by defective parts not manufactured by us, are not covered under this warranty.

- THE TERMS OF OUR WARRANTY ARE AS FOLLOWS:
- A. RAIL TONNEAU SYSTEM HARDWARE KIT (CLAMPS, RAILS, BOWS) FULL LIFETIME OF OWNERSHIP BY THE ORIGINAL PURCHASER.
 - B. TONNEAU COVER IS WARRANTED FOR ONE YEAR FROM THE DATE OF PURCHASE.
 - C. GAS STRUTS WARRANTED FOR 2 YEARS FROM DATE OF PURCHASE.

ANY IMPLIED WARRANTIES OF MERCHANTABILITY AND/OR FITNESS FOR A PARTICULAR PURPOSE CREATED HEREBY ARE LIMITED IN DURATION AS THE EXPRESS WRITTEN WARRANTY. OUR COMPANY SHALL NOT BE LIABLE FOR ANY INCIDENTAL OR CONSEQUENTIAL DAMAGE, INCLUDING, WITHOUT LIMITATION, DAMAGES RESULTING FROM THE USE OF THE PRODUCT ON REPAINTED SURFACES (NON-FACTORY ORIGINAL PAINT) AND FADING AND PAINT COLORATION DIFFERENCES RESULTING FROM THE PRODUCTS SHIELDING PORTIONS OF SURFACES FROM EXPOSURE TO THE SUN AND ELEMENTS WHILE OTHER ADJACENT SURFACES REMAIN COMPLETELY EXPOSED. THIS WARRANTY IS LIMITED TO FUNCTIONALITY OF PRODUCT, NOT COSMETIC RELATED ISSUES.

Some states do not allow limitations on how long an implied warranty lasts, or the exclusion or limitation of incidental or consequential damages, so the above limitations or exclusions may not apply to you. This warranty gives you specific legal rights, and you may also have other rights which vary from state to state. For further information or request for warranty work, please contact:

The Ultra-Lift Rail Tonneau System is designed to assemble easily in about 30 Minutes.

Be Sure your truck is clean.

FRAME RAIL ASSEMBLY

Step 1.

Remove paper from the foam tape on the rails. Lay out the frame on the pick-up truck bed.

Be sure the end marked "rear" is at the end of the truck bed.

Be sure the side rail with the short hinged section is placed at cab end. **See Figure 1.**

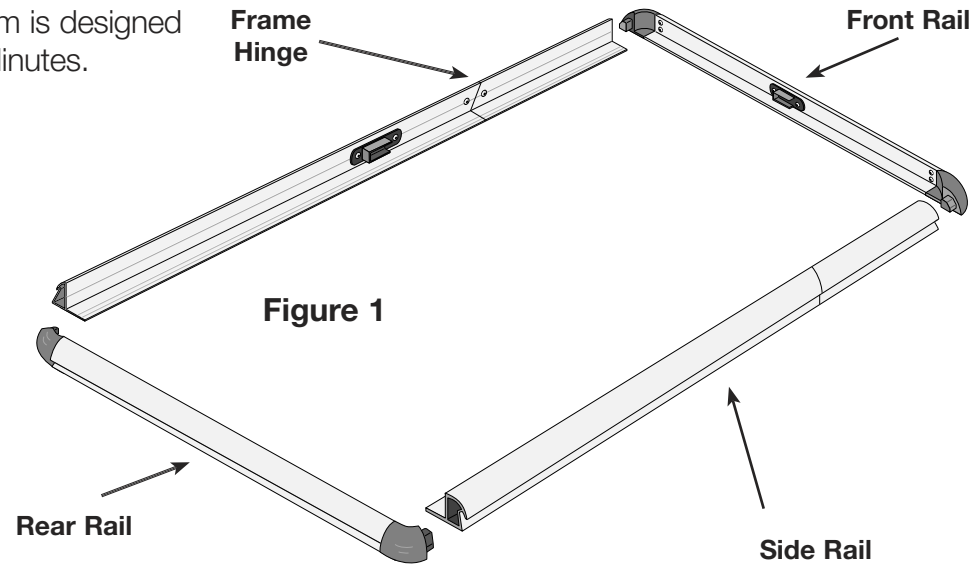

Figure 1

Step 2.

Fit the corners of the frame together and secure with two set screws in each end. Please use the pre-drilled holes for attachment to the frame.

See Figure 2.

ATTACH FRAME TO BED

Step 3.

Center the frame on the truck bed. Be certain the inside edge of the front rail is flush with the front edge of the truck bed.

Clamp the front "eight inch" section of the side rails (nearest the cab) to the truck bed with one clamp on each side. (If you have a bed liner, see the suggestions at the top of the next page.) Tighten the clamps at this time making sure the frame is square on the truck bed. **See figure 3.**

You are now ready to install the shocks.

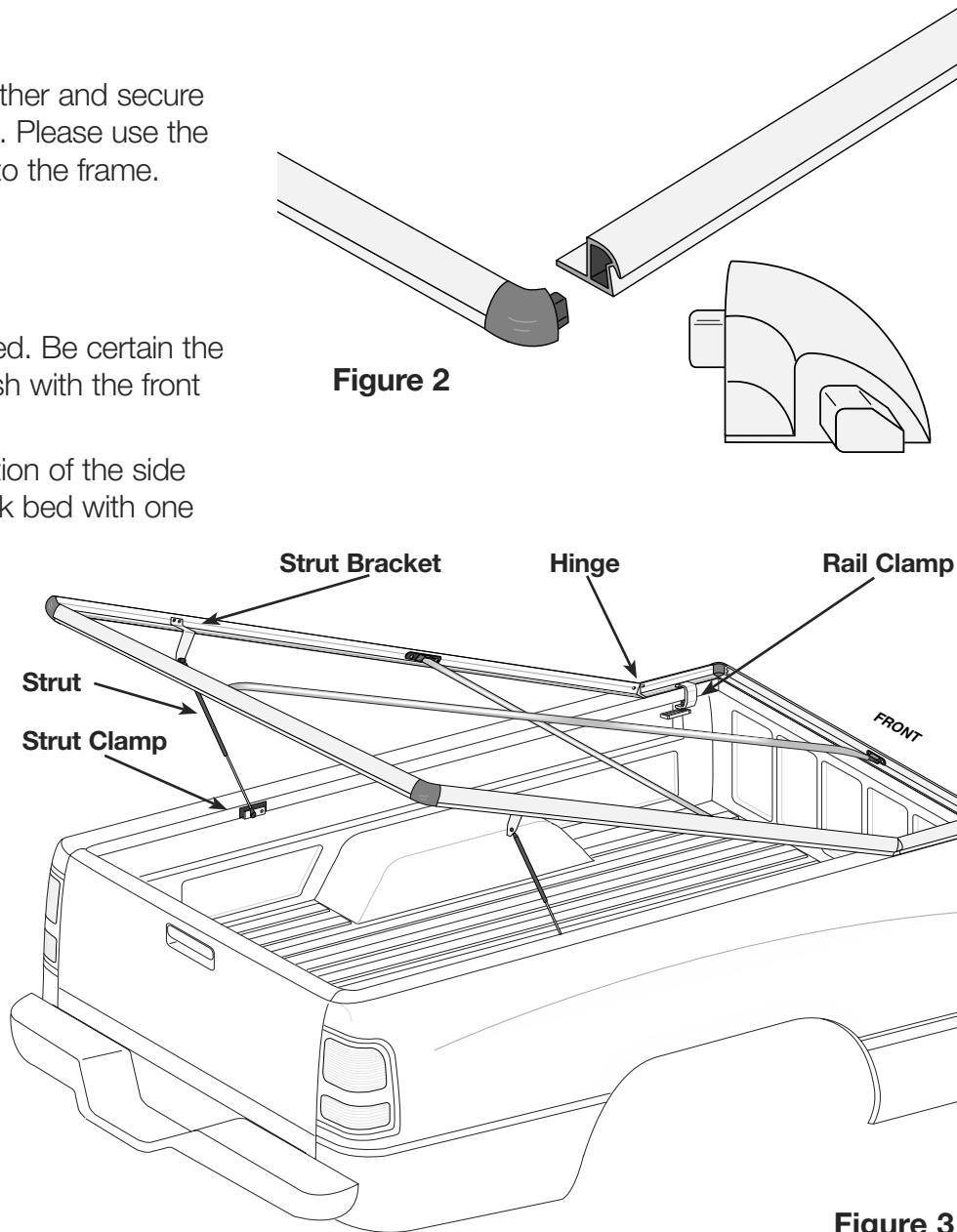

Figure 3

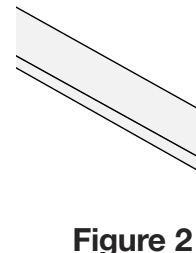

Figure 2

SUGGESTIONS FOR MOUNTING TOP MOUNT RAIL TONNEAU COVER WITH A BEDLINER
 These are only suggestions. There are many different types of bedliners on the market and no simple guidelines can be established. **Saddleman is not responsible for modifications made to bedliner resulting from Rail Tonneau installation.**

Under The Rail Bedliner:
 Front: In some cases it may be necessary to trim the front edge off the bedliner. If the front edge of the liner rises up above the truckbed and interferes with the weather stripping on the front rail, the liner must be trimmed.
 Affix a "U-channel" aluminum extrusion (not included) to prevent weakening or warping of bedliner after trimming.

Over The Rail Bedliner:
 Remove T-handles from the rail clamp (top right illustration). In order to do this, remove plastic end cap on either side of T-handle.
 Using rail clamps, strut clamps and snap clamps as a guide, mark each clamp location and notch out bedliner (bottom right illustration for rail clamp). Reinsert clamps.
 Rail system is now ready for a typical installation. The only exception is that now the rail clamps will need to be tightened using a wrench.

INSTALLING THE GAS STRUTS

STEP 4.

Attach the strut brackets to the side rails. Use the screws that are already in the side rails near the back of the frame. Tighten the strut bracket.

Attach the strut clamp and install it on the lip of the truck's bed rail. Position the front edge of the clamp 10.5 inches from the center of the strut bracket. **(See Figure 4)**

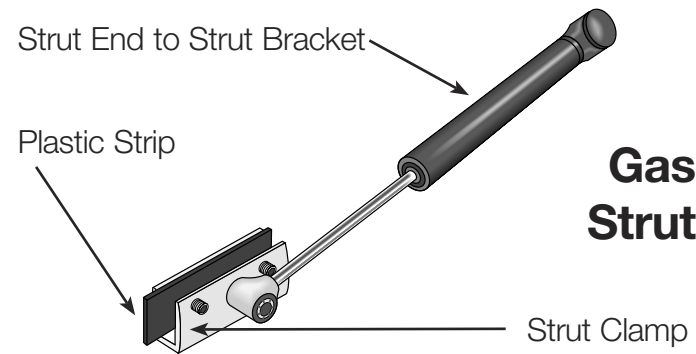

Be sure to place the black plastic strip between the set screws and your bed to prevent any paint damage. Tighten the clamp with the Allen wrench included.

DO NOT OVER TIGHTEN

Figure 4

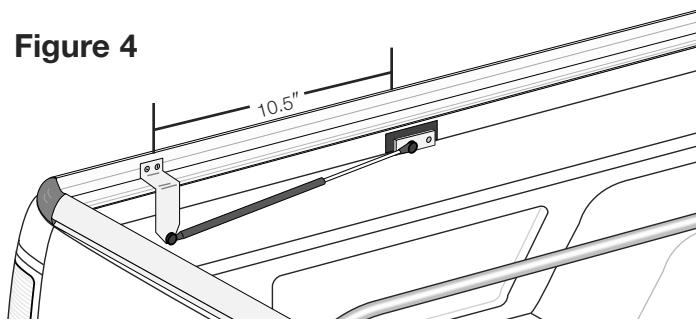

STEP 5.

Pull out the end caps on the struts. This will allow them to fit over the **strut bracket and strut clamp ball**.

Attach the strut (black cylinder end) to the strut bracket mounted on the rail. Replace the end caps on this portion of the strut.

Lift the rail tonneau frame. Attach the strut (silver rod end) to the strut clamp mounted on the lip of the truck bed rail. Replace the end caps on this portion of the strut.

The struts are now attached.

TO LOWER THE RAIL FRAME ALWAYS USE TWO HANDS AND APPLY EVEN PRESSURE.

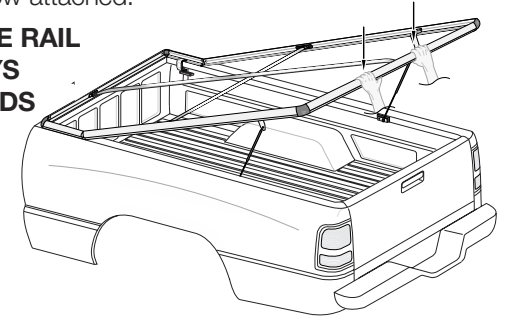

INSTALLING THE BOW

STEP 6.

Fit cross bow first by sliding into black brackets. Then install front to rear bow the same way.

